



Daylight Harvesting & Dimming Electronic Ballast

Ballast Specifications

120V and/or 277V
2, 3, & 4-Lamp Ballast
The Future of Fluorescent Lighting

3 & 4-Lamp Ballast Dimensions

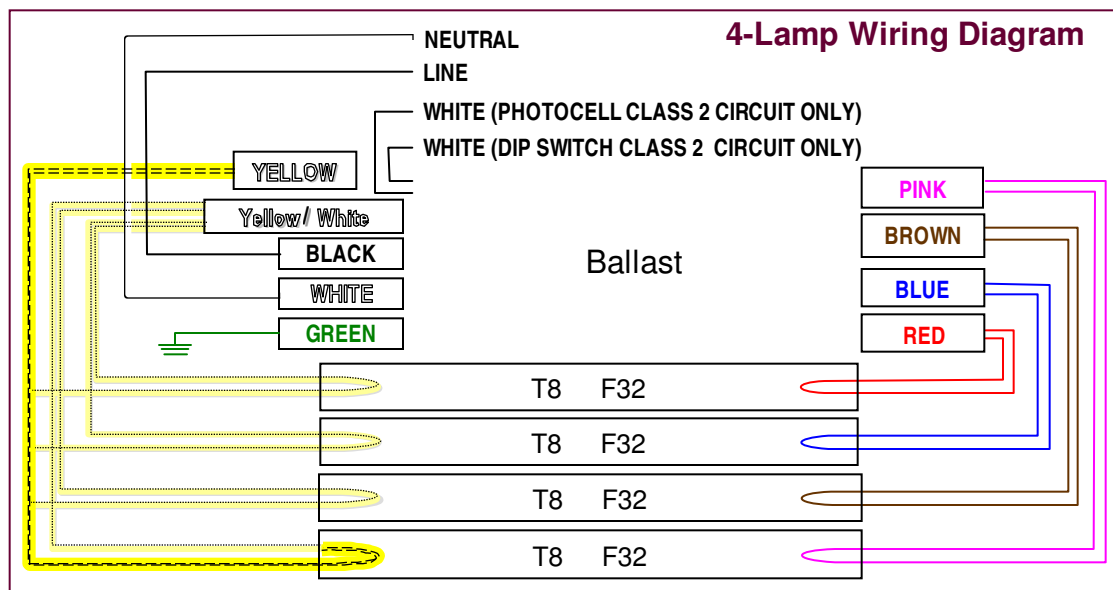
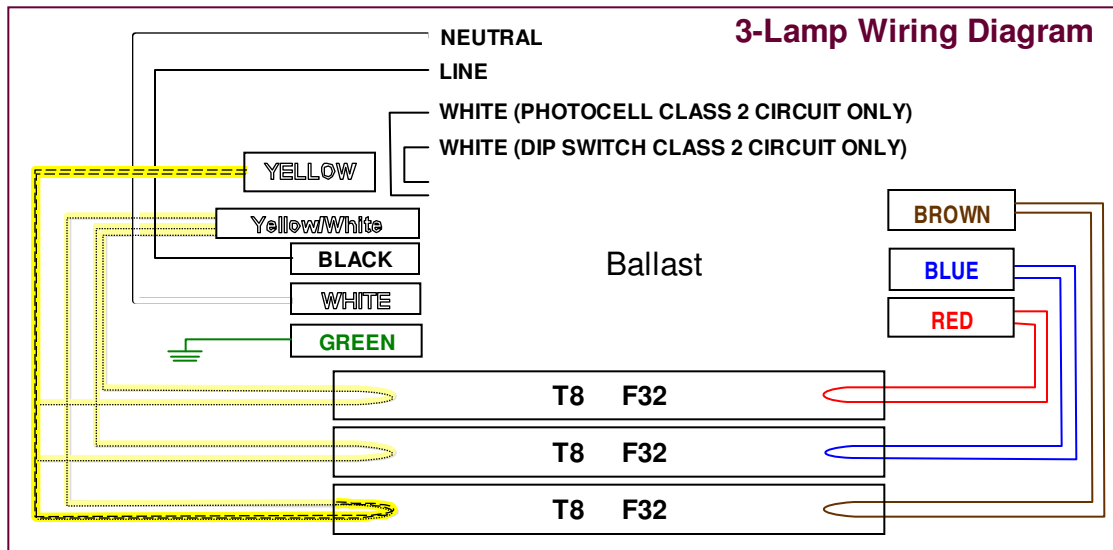
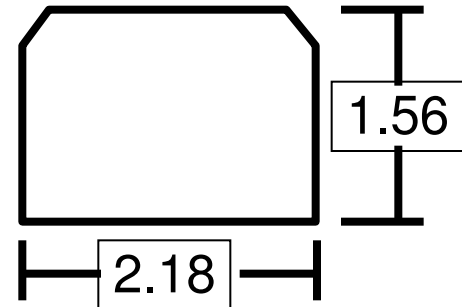
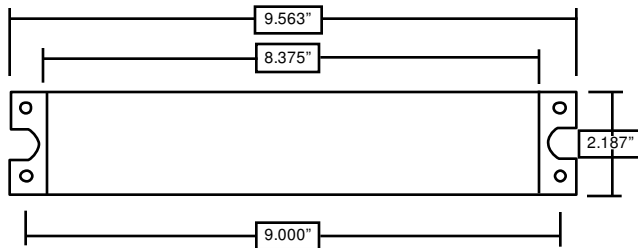



Daylight
Harvesting
&
Dimming Electronic Ballast

Ballast Specifications

120V and/or 277V
2, 3, & 4-Lamp Ballast
The Future of Fluorescent Lighting

2-Lamp Ballast Dimensions

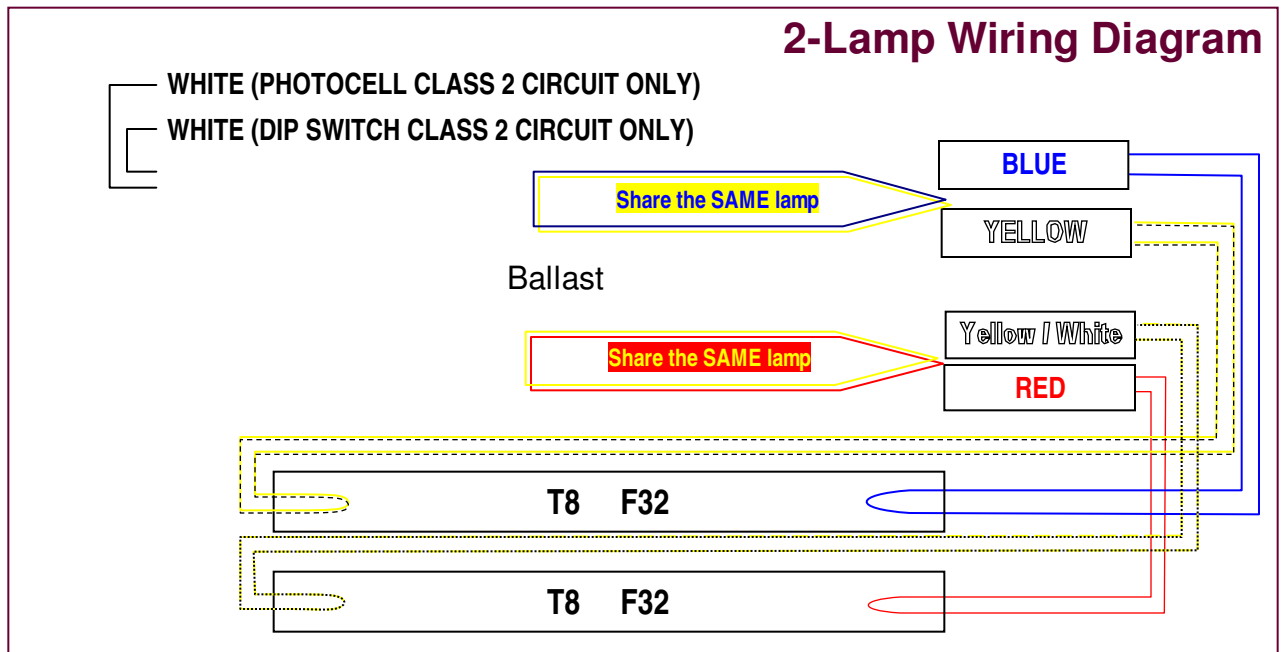
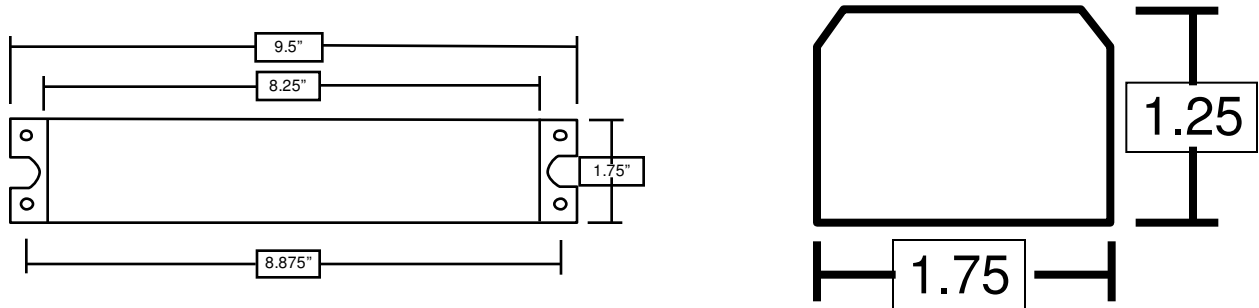



Daylight
Harvesting
&
Dimming Electronic Ballast

Ballast Specifications

120V and/or 277V

2, 3, & 4-Lamp Ballast

The Future of Fluorescent Lighting

1. Ballast shall be high frequency electronic operating lamps above 20 kHz frequency.
2. Ballast shall be capable of manual setting of fixed dimming level reductions of 10%, 20%, 30%, 40%, and 50% by means of an integral adjustment switch. The adjustment switch shall be easily accessed inside the luminaire without removal of the ballast cover.
3. Ballast shall be equipped with a compact integral photocell for daylight harvesting control. The photocell shall install in the ceiling by means of a simple "poke-through" design and shall be easily secured by a room side flange nut and plenum side pressure clip.
4. Ballast shall have a Lamp Crest Factor of 1.7 or less per ANSI C82.11-1993.
5. Ballast shall be UL/ CSA listed, Class P, Type 1 Outdoor.
6. Ballast shall operate in ambient temperatures of up to 40OC (105OF) without damage.
7. Ballast shall comply with FCC 47CFR Part 18 Non-Consumer for EMI and RFI.
8. Ballast shall tolerate voltage and frequency variations of "10% while operating at 60Hz, 120V and 277V input.
9. Ballast shall operate without visible flicker through the operating dimming range.
10. Ballast shall be manufactured in an ISO9002 facility.
11. Ballast shall have a power factor greater than .98 for the primary lamp at full output.
12. Ballast shall tolerate sustained open and short circuit output conditions without damage.
13. Ballasts shall be rapid start consistent with ANSI standard C82.11-1993
14. Ballasts shall not have any PCB's.
15. Input Current Total Harmonic Distortion shall not exceed 10% for the primary lamp at full output.
16. Ballast manufacturer shall provide a limited warranty against defects in material or workmanship, including replacement, for five years from the date of manufacture.
17. Ballasts will be operable with standard wall switches or relays.
18. Ballasts shall be compatible with power line carrier systems.
19. All lamps shall remain on at minimum light levels.
20. Ballast shall operate fixed level control and daylight harvest dimming control without the use of any external wiring or controls; all control will be integral to the ballast.





Daylight
Harvesting
&
Dimming Electronic Ballast

Ballast Specifications

120V and/or 277V

2, 3, & 4-Lamp Ballast

The Future of Fluorescent Lighting

4-Lamp, Dual 120V / 277V Ballast

CATALOG NUMBER	LAMP QTY	INPUT VOLTAGE	DIP SWITCH SETTING	INPUT WATTS	INPUT AMPS	BALLAST FACTOR	POWER FACTOR
AX432B120/277	4	120	100%	107	0.89	0.80	99%
			90%	93	0.78	0.68	99%
			80%	88	0.73	0.63	98%
			70%	78	0.65	0.54	98%
			60%	75	0.63	0.52	98%
			50%	65	0.54	0.44	98%
			40%	59	0.49	0.38	98%
THD < 10% at full output							
Ballast Crest Factor 1.6							
Max Dimming with photocell – 80%							
AX432B120/277	4	277	100%	107	0.38	0.80	99%
			90%	93	0.34	0.67	99%
			80%	88	0.32	0.63	99%
			70%	78	0.28	0.54	99%
			60%	75	0.27	0.53	98%
			50%	65	0.23	0.44	98%
			40%	59	0.21	0.39	98%
THD < 10% at full output							
Ballast Crest Factor 1.6							
Max Dimming with photocell – 80%							

Ballast must be grounded in accordance with national and local electrical codes.

Ballast testing was performed in house using a regulated voltage supply. Electrical readings were measured using a Xitron Model #2503A Multi-Channel Power Analyzer. Lamps used in the testing were Philips F32T8/TL841 and were aged a minimum of 100 hours, prior to testing. Ballast must be grounded in accordance with national and local electrical codes.

Ballast housing is UL Listed for use in air-handling plenums for all models.

Disclaimer: Due to continuous product improvements, specifications are subject to change without notice





Daylight
Harvesting
&
Dimming Electronic Ballast

Ballast Specifications

120V and/or 277V

2, 3, & 4-Lamp Ballast

The Future of Fluorescent Lighting

2-Lamp, 120V or 277V Ballast

CATALOG NUMBER	LAMP QTY	INPUT VOLTAGE	DIP SWITCH SETTING	INPUT WATTS	INPUT AMPS	BALLAST FACTOR	POWER FACTOR
AX232B120	2	120	100%	64	0.53	0.99	99%
			90%	58	0.49	0.89	99%
			80%	55	0.46	0.82	98%
			70%	49	0.41	0.67	98%
			60%	47	0.40	0.63	98%
			50%	41	0.35	0.48	98%
			40%	37	0.32	0.41	98%
			23	0.22	0.24	96%	
AX232B277	2	277	100%	66	0.24	0.99	99%
			90%	61	0.22	0.90	99%
			80%	57	0.21	0.83	99%
			68%	50	0.18	0.68	99%
			60%	48	0.18	0.64	98%
			50%	41	0.15	0.49	98%
			40%	37	0.14	0.35	98%
			18	0.07	0.18	96%	

THD < 10% at full output
Ballast Crest Factor 1.6

Max Dimming with photocell – 80%

3-Lamp, Dual 120V / 277V Ballast

CATALOG NUMBER	LAMP QTY	INPUT VOLTAGE	DIP SWITCH SETTING	INPUT WATTS	INPUT AMPS	BALLAST FACTOR	POWER FACTOR
AX332B120/277	3	120	100%	88	0.74	0.99	99%
			90%	79	0.67	0.89	99%
			80%	73	0.62	0.79	98%
			70%	63	0.53	0.69	98%
			60%	60	0.50	0.59	98%
			50%	51	0.43	0.49	98%
			40%	46	0.38	0.36	98%
			29	0.24	0.18	96%	
AX332B120/277	3	277	100%	90	0.33	0.99	99%
			90%	82	0.30	0.90	99%
			80%	74	0.27	0.80	99%
			70%	65	0.23	0.70	99%
			60%	63	0.23	0.60	98%
			50%	54	0.20	0.50	98%
			40%	48	0.18	0.36	98%
			28	0.25	0.19	96%	

THD < 15% at full output
Ballast Crest Factor 1.6

Max Dimming with photocell – 80%

THD < 10% at full output
Ballast Crest Factor 1.6

Max Dimming with photocell – 80%

